

VEMCO VR60 RECEIVER

HARDWARE MANUAL

12-12-2011

Copyright © 2011 by VEMCO
A Division of AMIRIX Systems Inc.

AMIRIX Systems Inc. Warranty and Disclaimer

WARRANTY

AMIRIX Systems Inc., doing business under its trade name VEMCO, provides a one (1) year warranty period for the Product from date of shipment.

VEMCO warrants that on the date of shipment all Products manufactured by VEMCO are free from defects in material and workmanship under normal use and service. This warranty applies to the components necessary for equipment upgrades, i.e. the VR1/VR2 to VR2W upgrade. With respect to transmitter products, while VEMCO is able to predict battery life with some certainty, VEMCO cannot guarantee that these Products will remain functional while submerged for extended periods of time. This warranty does not apply to any equipment, materials or design supplied by Buyer or a third party; re-battery services provided by VEMCO; Products for which VEMCO has not received payment; problems that results from: external causes such as accident, abuse, misuse; servicing not authorized by VEMCO; usage not in accordance with Product instructions; failure to follow the Product instructions or failure to perform preventative maintenance; usage of accessories, parts or components not supplied by VEMCO.

This warranty shall survive delivery only on the conditions and subject to the limitations set forth below.

NOTICE PERIODS

To receive a warranty remedy for a Product, Buyer must contact VEMCO's Customer Support Department during the warranty period to receive the Return Material Authorization ("RMA") instructions. Each defective Product returned for warranty remedy must be shipped at the Buyer's expense according to the RMA instructions and must include reasonable proof that the claimed defect is due to a matter embraced within the warranty set forth above and that such defect did not result from any act or omission of Buyer, including but not limited to any failure to operate and maintain the Product in accordance with VEMCO's applicable written instructions.

REMEDY

VEMCO's liability, and the Buyer's exclusive remedy under this warranty, as to a defect in material or workmanship, is limited to the repair of such defect in the accessory, equipment or part in which the defect appears or, at VEMCO's option, to the replacement of such accessory, equipment or part with a similar item free from defect. As to any item repaired by VEMCO or furnished as a replacement by VEMCO, VEMCO's liability and the Buyer's exclusive remedy to the repair or replacement of such item for any further defect in material or workmanship, provided VEMCO receives written notice at Halifax, Nova Scotia, of such further defect from BUYER within ninety (90) days after the repaired or replaced item is shipped to BUYER and provided that BUYER returns same to VEMCO as provided under "Notice Periods".

RETURNED ITEMS

All repairs, replacements and corrections described above shall be performed by VEMCO at its plant at Halifax, Nova Scotia, or at such other place as may be mutually agreeable, and with reasonable care and dispatch in order that the Product, accessory, equipment or part will not be kept out of service longer than necessary. Return to BUYER of a repaired, replacement, or corrected accessory, equipment, part or Product shall be at VEMCO's expense. Title to and risk of loss of the Product, accessory, equipment, or part returned to VEMCO pursuant hereto shall at all times remain with the BUYER, except that title to a returned accessory, equipment, part, or Product shall pass to VEMCO concurrently with shipment to BUYER of any item furnished by VEMCO to BUYER as a replacement therefore. VEMCO shall have only such responsibility for any Product, accessory, equipment, or part owned by the BUYER and in the possession of VEMCO as is chargeable by law to a bailee for hire, but shall not be chargeable for loss of use thereof.

WEAR AND TEAR

Normal wear and tear and the need for regular maintenance shall not constitute a defect under this warranty.

DISCLAIMER AND RELEASE

THE WARRANTIES, OBLIGATIONS AND LIABILITIES OF VEMCO AND THE REMEDIES OF BUYER SET FORTH HEREIN ARE EXCLUSIVE AND IN SUBSTITUTION FOR, AND BUYER HEREBY WAIVES AND RENOUNCES, ALL OTHER WARRANTIES AND OBLIGATIONS OF VEMCO AND ANY ASSIGNEE OF VEMCO AND ALL RIGHTS, CLAIMS AND REMEDIES OF BUYER AGAINST VEMCO, EXPRESS OR IMPLIED, ARISING BY LAW OR OTHERWISE, WITH RESPECT TO ANY NON-PERFORMANCE OR DEFECT IN THE PRODUCT OR IN ANY OTHER THING DELIVERED UNDER THIS AGREEMENT, INCLUDING BUT NOT LIMITED TO:

- (A) ANY IMPLIED WARRANTY OF MERCHANTABILITY OR FITNESS FOR A PARTICULAR PURPOSE;
- (B) ANY IMPLIED WARRANTY ARISING OUT OF COURSE OF PERFORMANCE, COURSE OF DEALING OR USAGE OF TRADE;
- (C) ANY OBLIGATION, LIABILITY, CLAIM OR REMEDY IN TORT, WHETHER OR NOT ARISING FROM THE NEGLIGENCE OF VEMCO OR ANY ASSIGNEE OF VEMCO, ACTUAL OR IMPUTED;
- (D) ANY OBLIGATION, LIABILITY, RIGHT, CLAIM, OR REMEDY FOR LOSS OF OR DAMAGE TO THE PRODUCT, FOR LOSS OF USE, REVENUE, OR PROFIT WITH RESPECT TO THE PRODUCT; OR FOR ANY OTHER DIRECT, INCIDENTAL OR CONSEQUENTIAL DAMAGES; AND
- (E) VEMCO MAKES NO REPRESENTATION THAT THE PRODUCT WILL NOT INFRINGE ANY PATENT OR OTHER RIGHTS OF ANY PERSON AND BUYER AGREES TO INDEMNIFY VEMCO AND HOLD VEMCO HARMLESS FROM ANY AND ALL CLAIMS AND LIABILITIES WITH RESPECT TO SAME TOGETHER WITH ANY CLAIMS AND LIABILITIES WITH RESPECT TO ANY INFRINGEMENT OF ANY PATENT OR OTHER RIGHTS OF ANY PERSON ARISING AS A RESULT OF BUYER'S PRODUCTS, TECHNOLOGY, ACTIVITIES, OR OTHERWISE.

LICENSE AGREEMENT

VEMCO grants to the Buyer a limited, personal license, with no right to sub-license, to use the Intellectual Property ("IP") and Embedded Software in the manner set out in the Documentation. The Embedded Software and IP are not sold to Buyer. All property rights, including Intellectual Property Rights, remain with VEMCO. All rights related to the Embedded Software not expressly licensed to the Buyer are reserved to VEMCO. BUYER shall not permit any person other than BUYER and its employees to use or make use of the Embedded Software and/or IP. BUYER shall not, and shall not permit any third party to, modify, adapt, translate, reverse engineer, decompile, disassemble, or create derivative works based on the Embedded Software and/or IP. This license is assigned to the Product with which you have acquired the Embedded Software and/or IP. If the Product purchased is a Transmitter product, be advised that the license life is equal to the operational life.

EXPORT

Products and associated materials supplied or licensed hereunder may be subject to various export laws and regulations. It is the responsibility of BUYER to comply with such laws and regulations.

NEGOTIATED AGREEMENT

It is fully understood by the parties that the price of the Product and other mutual agreements of the parties set forth in this agreement were arrived at in consideration of this warranty, SPECIFICALLY INCLUDING THE WAIVER, RELEASE AND RENUNCIATION BY BUYER SET FORTH ABOVE (DISCLAIMER AND RELEASE).

© (2011) AMIRIX Systems Inc. All rights reserved. The information contained herein includes information which is confidential and proprietary to AMIRIX Systems Inc. and may not be used or disclosed without prior written consent of AMIRIX Systems Inc.

TABLE OF CONTENTS

INTRODUCTION	1
ABOUT VEMCO	1
SYSTEM OVERVIEW	1
HARDWARE	2
VR60 RECEIVER	2
Power Switch and Fuses	2
To Open the VR60 Case	2
Gain Control	2
Signal Level	3
Channel Selection	3
Volume Control	3
Data Output	3
INSTALLATION	4
Inspection	4
Installation	4
OPERATION	4
Telemetry Transmitters Application	4
Tracking and Locating Applications	4
AVAILABLE VR60 RECEIVER OPTIONS	5
DECODER/DISPLAY UNIT (OPTION 01)	5
Hardware Features (Option 01)	6
Keypad	6
Display	6
Serial Port Configuration	6
External Control	7
Low Power Supply Warning	8
Operation of Decoded Display	8
Decode	9
Decode Transmitters	9
Decode Period	10
Pulses per Minute	11
Set Frequency	11
Setup	12
Time of Day	12
Printer	12
Log Interval (Option 03B)	13
Blanking Interval	13
Transmitters Setup	14
Converting Units	17
INTERNAL BATTERY (OPTION 02)	18
VR60 MEMORY (OPTION 03B)	19
Memory Storage Capacity	19

Log Setup	20
Decoding and Logging	21
Retrieve Data from Memory	22
View Data	23
Print Data	23
Erase Data	24
Dump Data	24
Normal Download of Data (non-compressed)	24
Binary Download of Data (compressed)	25
Battery Replacement on the Memory Board	26
EXTENDED CABLE (OPTION 04)	26
CODED TRANSMITTER (OPTION 07)	27
Transmitter Type	28
Coded Channels	29
NON-STANDARD PRESELECTED FREQUENCIES (OPTION 08)	30
AVAILABLE SOFTWARE PROGRAMS	31
SOFTWARE PROGRAMS	31
OPTION COMBINATIONS AND APPLICABLE SOFTWARE	32
Setup of VR60 Receiver Software	32
APPENDIX	33
GLOSSARY	33
Log Interval	33
Print Interval	33
HARDWARE SPECIFICATIONS	34
VR60 RECEIVER SPECIFICATIONS	34
VH65 OMNIDIRECTIONAL HYDROPHONE (50-80kHz)	35
V10 DIRECTIONAL HYDROPHONE (50-80kHz)	36
VH32 OMNIDIRECTIONAL HYDROPHONE (25-35kHz)	36
V11 DIRECTIONAL HYDROPHONE (25-35kHz)	37
CODED CHANNELS (order specific)	38
SYSTEM DIAGRAMS	39

INTRODUCTION

ABOUT VEMCO

VEMCO, a division of AMIRIX Systems Incorporated, is a leader in the design and manufacture of oceanographic research tools and systems since 1979. Located on the shores of Shad Bay, Nova Scotia, VEMCO's product line ranges from miniature acoustic transmitters and data loggers to large tracking, positioning, and monitoring systems. Data communication methods include acoustic telemetry, radio modem and cellular telephone modem.

Please contact us at:

VEMCO Division
AMIRIX Systems Inc.
211 Horseshoe Lake Drive,
Halifax, Nova Scotia,
Canada B3S 0B9

Phone: 902-450-1700
Fax: 902-450-1704
Email: sales@vemco.com
Web page: www.vemco.com

SYSTEM OVERVIEW

The VR60 Ultrasonic receiver is intended to receive underwater signals transmitted from pingers, location markers, data telemetry transmitters, and other similar devices over a frequency range of 10 kHz to 100 kHz. The VR60 receiver is designed to operate with a hydrophone containing a high gain, low noise pre-amplifier powered by the receiver. An omnidirectional test hydrophone is provided as a standard accessory (VH65). An optional V10 or other directional hydrophone, when used with the signal strength indicator on the receiver front panel, enables the VR60 receiver to locate and track a transmitter.

An optional *Decoder/Display* unit (Option 01) provides pulse interval timing and alphanumeric display of transmitted data, such as depth in meters or temperature in degrees Celsius. A serial RS-232C compatible interface provides communication to, or control by, a remote terminal or general purpose computer. The serial interface can also be connected to a printer to log data on paper.

A VR60 receiver equipped with 256K of memory (Option 03B) is capable of saving received data for later viewing on the receiver or downloading to a computer.

Data from coded transmitters can be received when the VR60 receiver has been equipped with coded capabilities (Option 07). This allows the receiver to detect a larger number of transmitters on a single frequency.

HARDWARE

VR60 RECEIVER

Power Switch and Fuses

The power switch has four positions, OFF, ON, CHG (Charge) and AUX. The VR60 receiver is powered with a 12-15 VDC power supply.

If the internal battery (Option 02) is installed in the VR60 receiver, the ON position will power the receiver from the internal battery. The internal battery receives a float charge if an external power supply is connected when the power switch is in the ON position (**do not** connect the external power with the power switch in the ON position). To charge the internal battery with the receiver not in operation, move the switch to the CHG (Charge) position as explained in the *Internal Battery (Option 02)* section of this manual. The AUX position on the ON switch will power the VR60 receiver from an external power source without float charging the internal battery.

The main system fuse (1 A) is located on the receiver controller circuit board. A fuse (80 mA) for an independent hydrophone is located on the VR60 receiver's front panel (top left corner). If fitted with an internal battery (Option 02), a fuse (1 A) is also located on the charge regulator board.

To Open the VR60 Case

To open the VR60 receiver case, six mounting screws on the front panel and two rubber feet must be removed. The rubber feet that must be removed are on the same side of the VR60 case as the lid closure clips, and are the two furthest from the clips. After the six mounting screws and two rubber feet are removed, slowly pull the VR60 chassis from the case using the two handles. If the internal battery has been installed (Option 02), be careful of the battery cable while removing the chassis.

Gain Control

The VR60 receiver gain may be controlled automatically by placing the front panel switch in the AUTO position. When in automatic gain mode, the gain begins at the setting selected on the rotary switch marked GAIN (dB) at the time the receiver was powered.

For tracking and locating applications, the gain may be manually controlled by placing the front panel switch in the MANUAL position and using the rotary switch marked GAIN (dB) to set the gain. The gain may be set in six decibel (6dB) increments, beginning at zero.

Signal Level

A signal level meter, located on the front panel, indicates the amplitude of each received pulse. This indicator is used with the manual gain control and a directional hydrophone for tracking and locating applications. When the indicator is at full scale, the manual gain should be reduced so meter variations will indicate transmitter direction as the hydrophone is turned. If the signal level indicator is at the bottom of the scale, the gain should be increased to detect meter variations.

Channel Selection

The front panel switch labeled CHANNEL controls the preselected frequencies for the receiver. The eleven preselected frequencies are listed on a plate either on the front panel or on the inside of the case lid. These frequencies are also listed in the *VR60 Receiver Specifications* section of the Appendix. If the receiver has the decoder/display (Option 01), the frequency can also be selected with the keyboard when the Channel switch is in the external (EXT) position (see *Set Frequency Command*).

Volume Control

The front panel control marked VOLUME allows the audio output level (volume) to be adjusted. The volume increases as the knob is turned clockwise. The volume may be turned down (fully counterclockwise) during data telemetry applications where audio indications are not required. In tracking applications the audio level can be used instead of, or in conjunction with, the signal level indicator to determine when signals are strongest (i.e. when the hydrophone points directly at the transmitter).

Data Output

A BNC connector on the front panel provides a TTL compatible logic signal (high during pulse detection) of approximately 150 ms duration. A front panel LED provides a visual indication of each detected pulse.

INSTALLATION

Inspection

Unpack and inspect the equipment as soon as possible. Check that all parts and accessories are included. Determine if any damage was incurred during shipment and, if so, report to the transportation company immediately as it is their responsibility.

Installation

Secure the receiver in a dry place and connect the external power cable to a 12VDC power source (if necessary). Connect the red wire on the power cable to the positive on the power supply and the black wire to the negative. Deploy the hydrophone (see instructions included with directional hydrophone, if used), and connect the hydrophone connector to the front panel of the receiver (DO NOT connect a hydrophone while the receiver is powered).

OPERATION

Telemetry Transmitters Application

Set the rotary gain switch to mid position (36dB) and set the gain switch to AUTO. Select the correct channel (frequency) for the transmitter to be received, and switch on the power. A short time should be allowed for the Automatic Gain Control (AGC) to lock on to the transmitter amplitude. After the AGC is locked on the transmitter amplitude, the front panel LED will flash for each received pulse. The volume control may be adjusted to a comfortable level without affecting the signal detection process. If the *Decoder/Display* unit (Option 01) has been installed in the VR60 receiver, refer to instructions on data telemetry found in the *Decode Transmitters* section.

Tracking and Locating Applications

Set the gain switch to manual position, and set the rotary switch to mid position (36dB). Select the appropriate channel (frequency) for the transmitter to be received, and switch on the power. Adjust the rotary gain switch so the signal level indicator reads approximately mid scale. Rotate the directional hydrophone slowly past the transmitter direction and observe the increase in the signal level shown on the signal level meter when the hydrophone is pointing towards the transmitter. The audio signal also increases as the signal level increases. Either, or both, of these indicators may be used for the direction to travel in when tracking a transmitter. Make sure that the gain is adjusted appropriately for best results (see *Gain Control* section).

AVAILABLE VR60 RECEIVER OPTIONS

There are seven options available with the VR60 receiver. These options are listed below, and are explained in detail in the sections to follow.

- Option 01: Internal Telemetry Decoder and Display.
- Option 02: Internal rechargeable battery (AC charger module also supplied).
- Option 03B: 256K CMOS Memory with independent battery backup and data logging firmware (requires Option 01).
- Option 04: Additional hydrophone cable length available at time of manufacture.
- Option 07: Coded transmitter capability.
- Option 08: Non-standard preselected frequencies in the CHANNEL switch.

It is possible to combine certain options in the same receiver. For example, a VR60 receiver equipped with Options 01, 02, and 03B has an internal power source and is capable of decoding and displaying data during a monitoring cycle, while storing the data to memory. Some options are prerequisites of others, and not all options are compatible with each other. An option with a lower number is a prerequisite of a higher numbered option, with the exception of Option 02 and Option 04, which may be included in a VR60 receiver regardless of other options. A complete list of option combinations is available in the *Available Software* section of this manual.

DECODER/DISPLAY UNIT (OPTION 01)

The *Decoder/Display* unit (Option 01) is installed in the VR60 receiver case with alphanumeric display and keypad for data entry and control. A serial communications port on the front panel allows control and data storage by an external general purpose computer, terminal, or printer.

The primary functions of the *Decoder/Display* unit (Option 01) are to time the arrival of ultrasonic pulses, extract any encoded data, and display the information on the LCD display. The time between pulses (or period) of a pinger is used for identification and is shown on the display in milliseconds (ms). Telemetry transmitters send information, such as temperature, depth, or speed, by encoding the data in the time between pulses. A microcomputer within the *Decoder/Display* unit (Option 01) uses manually entered calibration data to process the pulses and extract the encoded data. This calibration data is stored in non-volatile memory (see *Setup Decoder* section), and is not lost when the receiver is powered down. Calibration data may be entered for a maximum of twelve telemetry transmitters, each with up to two multiplexing data channels.

Hardware Features (Option 01)

Keypad

The keypad is used to control the functions of the *Decoder/Display* unit (Option 01) and to enter data during the setup procedure. Ten digit keys (0 to 9) and a minus sign provide for numeric data entry. The ENTER/YES key is used to enter the numeric data, or to answer YES to Yes/No (Y/N) questions. The NEXT/NO key allows cycling through lists of possible identifiers and units during setup, or to answer NO to Yes/No (Y/N) questions.

The two top right hand keys have dual functions. If pressed directly, the top right hand key (FREQ) will place the unit in *Set Frequency* mode (see *Set Frequency* section). If this key is pressed after the red shift key, the unit will be placed in the SETUP routine to set the real time clock and initialize various channel parameters.

The button below this, if directly pressed, will place the unit in DECODE mode for reception of pulses from the receiver (see *Decode* section). If this key is pressed after the red shift key, the unit logs data to an internal memory data storage module inside the VR60 receiver. The LOG function requires Option 03B. The red shift key is also a plus key (+), used to increment the channel frequency. The plus key is not used for entering a positive number.

Display

The display is a low power consumption LCD alphanumeric display of two lines, each containing a maximum of sixteen characters. This display is more clearly viewed from approximately twenty degrees below horizontal. The optimum viewing angle is factory set by adjusting a trimming potentiometer on an internal printed circuit board.

Serial Port Configuration

Serial data output is RS232C compatible (Signals: data in, data out, and GND only) and is wired as Data Communications Equipment (DCE). The 1.5 second delay after <CR> for 300 baud allows low cost thermal printers to be connected to the receiver. The specifications for each baud rate are described below:

BAUD RATE	9600	1200	300
CODE	ASCII	ASCII	ASCII
DATA BITS	Eight	Eight	Eight
PARITY	None	None	None
STOP BITS	One	One	Two
END OF LINE	<CR> <LF>	<CR> <LF>	<CR> (no <LF>)
DELAY AFTER <CR>	None	None	1.5 second

External Control

The *Decoder/Display* unit (Option 01) may be controlled from an external terminal or computer when connected to the VR60 receiver through a RS232 serial cable. To do so, turn on power and respond to the "KEYPAD (Y/N)" prompt with NO. The display will then show the default baud rate of 9600 baud with the Y/N prompt. If this is the desired baud rate then select YES on the keypad, otherwise select NO until the desired baud rate is shown and then select YES. The baud rate selections are 9600, 1200, and 300 baud. The display will then show:

ENTER COMMAND
TERMINAL MODE

All future commands may now be entered at the terminal keyboard. The following terminal keys are used to replace the front panel keypad. To return to keypad operation, the VR60 receiver must be powered down and powered up again.

EXTERNAL COMMANDS			
FUNCTION	KEYPAD	TERMINAL	OPTION
Decode	DECODE	D	
Setup	SHIFT SETUP	S	
Set Frequency	FREQ	F	
Log Data	LOG	L	-03B
Inspect Data Storage	SHIFT LOG SETUP	LS	-03B
Monitor	SHIFT 9	+9 or .9	-03B
Enter (YES)	ENTER (Y)	RETURN or Y	
Next (NO)	NEXT (N)	N	
0 - 9	0 - 9	0 - 9	
+	+	+ or .	-6
-	-	-	
.	+	+ or .	

NOTE: CTRL-C will reset the VR60 receiver and have the same effect as momentarily switching off the power.

Low Power Supply Warning

Two power safety thresholds are built into the VR60 receiver to ensure the setup parameters (which are stored in memory) are not altered in the event of a slow power failure. A slow power failure may occur when the 12 volt power supply gradually falls below 10 volts.

The first threshold contains a warning that the power supply voltage is low. The low voltage warning is indicated with the appearance of an asterisk "*" in the last position of the second line. In addition to the asterisk, the ENTER COMMAND display will be replaced by:

```
ENTER COMMAND
(Power is LOW) *
```

If the power supply voltage continues to decrease, the VR60 receiver will suddenly stop operating (second threshold). To restart the VR60 receiver, turn the power switch to off, connect a power supply with a voltage between 10 - 14.5 volts, and turn the power switch to ON.

Operation of Decoded Display

When using the keypad and display to operate the decoder functions of the VR60 receiver, there are two types of prompts. These prompts are explained in table below:

(Y/N)	The prompt shown on the display should be answered with either a YES or NO. Use the ENTER/YES key for YES and the NEXT/NO key for NO.
?	The prompt shown on the display requires a number (input on the keypad), usually followed with ENTER.

When the receiver is turned on, the display should read:

```
VR-60 X.XX YY
KEYPAD (Y/N)
```

where X.XX is the firmware version and YY is the option code (the version and option code information should be referred to when ordering further software options). To operate in the keypad mode, select YES on the keypad. The display should read "ENTER COMMAND". If NO is selected at the KEYPAD (Y/N) prompt, the decoder is under external control (see *External Control* section).

The possible functions at the ENTER COMMAND level are: Decode (see *Decode* section), Freq (see *Set Frequency* section), Setup (see *Setup* section), and Inspect Memory (see *VR60 Memory* section - Option 03B).

Decode

The *Decode* routine is used for decoding data telemetry transmitters # 1-12 whose calibration data and frequency have been previously entered during the *SETUP* routine (see *Setup* section), or for showing the raw time periods between incoming pulses. The period option is intended for identifying simple pingers, or calibrating data telemetry units, and does not support printer outputs or data logging. The structure for the decode routine is shown below, with a detailed description of each section to follow:

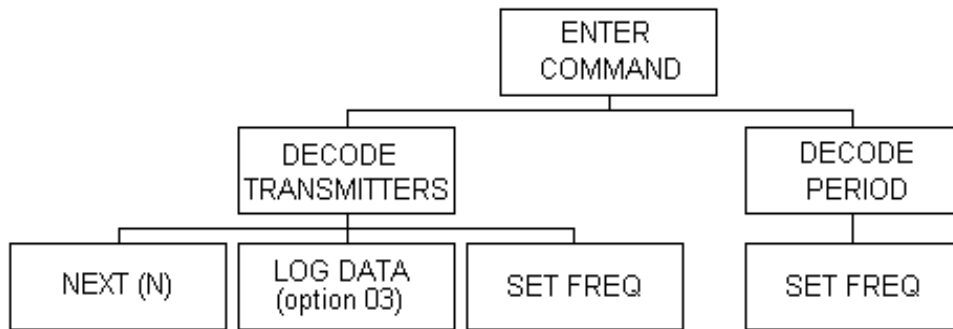

Decode Transmitters

Before data from a transmitter can be decoded, the calibration parameters must be stored in the transmitter calibration data setup routine (see *Transmitters Setup* section). After the calibration data has been entered, press the DECODE key on the keypad at the ENTER COMMAND prompt. The display will read:

TR #? (1-12)
(0 for Period)

Enter the transmitter number (1-12) followed by ENTER. The display will show:

DECODING TR# n where n is the transmitter number entered.

If the Channel rotary switch is in the EXT position, the frequency associated with the transmitter being decoded will appear in the second line. If the Channel switch is not in the EXT position, a warning will appear on the display. This warning indicates that the desired frequency is being overridden by the frequency set by the Channel switch. The switch must be at the EXT position for the transmitter to be received and decoded. If a printer is being used, this warning is also printed to avoid confusion during data analysis. Switching the channel rotary switch to EXT will select the frequency corresponding to the decoded transmitter and will momentarily show the frequency on the display.

When decoding a transmitter, the VR60 receiver will show “NO SIGNAL” on the display until a transmitter pulse is received. The LED on the front panel (below display) will flash to indicate that a signal has been received by the VR60 receiver and is being sent to the decoder. The data from the transmitter is displayed in the correct units, as assigned in SETUP. For example,

TEMP: 4 °C
DEPTH: 270 m

When decoding multi-channel transmitters, two error messages other than NO SIGNAL are possible, MISSING PULSE or LOST SYNC. These messages are the result of not receiving either a data pulse or a synchronization pulse, and are not sent to an attached printer.

The following features are available while decoding a transmitter:

6. The display unit returns to the ENTER COMMAND level by pressing ENTER.
7. The frequency can be changed by pressing the **FREQ** key (see *Set Frequency* section). After changing the frequency the VR60 receiver writes the new frequency to the printer port, and then resumes decoding.
8. The transmitter number and the time can momentarily be displayed by pressing **NEXT**.
9. The display will maintain its current value while any digit key is pressed, and will continue once the key is released.

Decode Period

The *Decode Period* option is primarily used to identify pingers, but may also be used in the calibration of telemetry transmitters. To enter the *Decode Period* option, press the **DECODE** key at the ENTER COMMAND prompt. The display reads:

TR #? (1-12)
(0 for Period)

Select the 0 key followed by the **ENTER** key (or just select **ENTER**) and the decoder will display the period in milliseconds (ms). The display will show “NO SIGNAL” until transmitted pulses are received.

The frequency can be selected with the Channel switch, or with the keypad when the Channel switch is in the EXT position. There are eleven preset frequency options available on the Channel switch, which are listed on the inside cover of the receiver. When the frequency is selected with the rotary switch, only the period is displayed with each pulse (the frequency is not shown). When the frequency has been selected with the keypad (see *Set Frequency* section), both the period and the frequency are displayed with each received pulse.

Pulses per Minute

The value of pulses per minute can be shown by using the *Decode* function. First, setup a transmitter (see *Transmitters Setup* section) with the following: frequency (as desired), Rep Rate, Slope = 60, Intercept = 0, No Decimal. Ignore the ID (Depth, Temp, etc.) and the units (m, ft, etc.) as neither applies to pulses per minute. Once the transmitter setup is complete, decode the appropriate transmitter number as described in the *Decode Transmitters* section.

Set Frequency

The frequency channel can be selected in 100 Hertz (Hz) increments ranging from 10.0 kHz to 99.9 kHz. To do so, position the Channel switch to EXT and press the **FREQ** key on the keypad. The display will show the current frequency (69.0kHz in the example below) in the first line. The second line indicates the choices available: yes, no, increment up, or increment down.

```
FREQ: 69.0 kHz  
(Y/N), UP, DOWN
```

The response is chosen from the following list:

- YES : frequency is OK; exit FREQ routine
- NO : change frequency (see below)
- + : increment frequency by 100 Hz
- : decrement frequency by 100Hz

If the response is “No”, the second line of the display requests the input of the new frequency. The question mark (?) indicates that a numeric entry must be made on the keypad. Enter the first three digits of the new frequency. For example, if the new frequency is to be 65.5kHz, enter the digits 6 5 5 on the keypad. The new frequency will be shown in the top line of the display and the (Y/N), UP, DOWN prompt is repeated on the second line.

If the panel switch is not on EXT, the display momentarily warns “FREQUENCY UNDER PANEL CONTROL”. The frequency is being determined by the switch position rather than the keypad entry.

Setup

The setup routine contains the following features:

1. Set internal time-of-day clock
2. Turn on/off the printer, set the print interval and baud rate.
3. Setup transmitter parameters (frequency, coding type, units, slope, intercept) for up to twelve transmitters. The transmitter parameters will remain in memory storage until changed.
4. Set logging interval. (Option 03B)

Enter the *Setup* mode by pressing the Shift key (red plus sign) and the SETUP key (top right corner of keypad). The routine will then move through the available selections in the following order: Time of Day, Printer, Log Interval (Option 03B), Blanking Interval, and Transmitters Setup. The sections of SETUP pertaining to Option 03B is explained in the VR60 Memory section of this manual.

Time of Day

The display shows the current time in the format days: hours: minutes: seconds (see example below). The second line in the display shows the Y/N prompt. Select YES if the time shown is correct, or select NO and follow the prompts to enter the correct time.

3: 8: 25: 16
TIME (Y/N)

The time of day should be reset each time the receiver is turned on if a printer is used, or if data logging (Option 03B) is employed.

Printer

After the date has been selected, the printer status will be displayed as either:

No Printer (Y/N) or Printer (Y/N)

If there is no printer or storage device connected to the serial port, select YES at the “No Printer (Y/N)” prompt. If a printed record of the data is desired, select NO at the “No Printer (Y/N)” and YES at the “Printer (Y/N)” prompt. If a printer is selected, the unit will display the print interval (time between printing data to the serial port) in seconds. The print interval may be changed by selecting NO at the (Y/N) prompt and then entering the new interval (between 0 and 100 seconds).

NOTE: When the print interval is zero all data is printed. For example, with a print interval of 10 seconds the data is only printed every 10 seconds.

With a printer selected, the unit will display the current baud rate. Press NEXT until the desired

baud rate is displayed (choice of 9600, 1200, or 300 baud). When the appropriate baud rate is displayed, press the ENTER key on the keypad.

Log Interval (Option 03B)

If data logging is included in the VR60 receiver (see *VR60 Memory (Option 03B)* section), a prompt for the Log Interval is shown on the display requesting verification that the Log Interval is correct.

LOG Int. 0 S
(Y/N)

The Log Interval controls the rate at which decoded data is sent to memory. The Log Interval may be between zero and 30000 seconds (over eight hours) and must be entered as seconds. A Log Interval of zero will store all the decoded data in memory. For example, if a Log Interval of one minute is desired, a value of 60 seconds must be entered. The decoded data will be stored to memory every 60 seconds even though the data may be changing at a faster rate on the display.

If the Log Interval is correct, select YES. To change the Log Interval, select NO and enter the desired value on the keypad (followed by ENTER).

Blanking Interval

The Blanking Interval is the time after each detected pulse in which echoes and reverberations are ignored. The Blanking Interval should normally be set to 200 milliseconds. In extremely reverberant areas the Blanking Interval may be increased but not to exceed 75% of the shortest transmitter period.

If a Blanking Interval of 200 ms is not desired, select NO at the (Y/N) prompt and enter the desired Blanking Interval on the keypad (followed by ENTER).

Transmitters Setup

The calibration data may be entered for up to twelve telemetry transmitters for use in the *Decode* mode (see *Decode* section). The VR60 receiver is shipped with the calibration data setup for any transmitters ordered with the receiver. Calibration data for other transmitters may be entered from the keypad, or with the appropriate software (see *Available Software* section). If calibration data is to be changed or added, select NO when the prompt shown below appears on the display. If the data does not require alteration then select YES.

TRANSMITTERS
SETUP OK (Y/N)

The transmitter calibration data is stored in memory so it needs to be entered only once for a particular transmitter. The setup of data is explained below in step form.

STEP 1: **Select transmitter #**

At the prompt “TRANSMITTERS SETUP OK (Y/N)”, select NO. The display will then show:

SETUP TR#?
(0 TO QUIT)

Enter a transmitter number on the keypad between 1 and 12, followed by ENTER. The display will then show:

TR n XX.X kHz
FREQ OK (Y/N)

where n represents the transmitter number just entered and XX.X represents the frequency.

STEP 2: **Select Frequency**

If the frequency shown is correct, select YES on the keypad. To change the frequency, select NO and input the new frequency.

STEP 3: **Select decoding type**

Press NEXT until the desired decoding type appears. Choose the appropriate type by selecting ENTER. The existing decoding types are: Interval, Two Channel CAI (Communication Associates Incorporated), Two Channel Interval, and Rep Rate.

STEP 4: Select ID

Press NEXT until the desired ID appears. The existing types are: DEPTH (depth), PRES (pressure), TEMP (temperature), COND (conductivity), SPD (speed), RATE (pulses per minute, etc.), and ANGL (angle). When the desired ID is shown on the display, press the ENTER key.

STEP 5: Select Units

Press NEXT until the desired unit for the ID type appears and then select ENTER. The units are labels only and do not convert the slope and intercept from one unit to another. For example, to change the units from meters to feet, the slope and intercept must be converted and entered in the VR60 receiver as feet. The available Units are shown in the table below:

AVAILABLE UNITS		
DEPTH	m	meters
	ft	feet
	fath	fathoms
PRES	psi	pounds per square inch
	bars	bars
	kg/M	kilograms per square meter
TEMP	°C	°C (degrees Celsius)
	°F	°F (degrees Fahrenheit)
COND	mmho R	milli mhos per centimeter conductivity Ratio
SPEED	mph	miles per hour
	knts	knots per hour
	m/S	meters per second
	rpm	revolutions per minute
RATE	ppm	pulses per minute
	Hz	cycles per second
	mSec	milliseconds

STEP 6: Select Slope and Intercept

The slope and intercept calibrated for each transmitter (listed in the Transmitter Specifications manual for the order) must be entered. The display will show:

S: XXX I: YYY
T n (Y/N)

where n is the transmitter number, XXX the slope and YYY the intercept. Press YES if the data shown is correct, or NO to enter the correct slope and intercept. If NO is selected, a prompt will appear on the display requesting the slope. Enter the slope without the decimal point and select ENTER. For example, a slope of 25.6 is entered as 2 5 6. The display then

prompts for the intercept. An intercept of -256, with the slope above, is entered as - 2 5 6 0. The choice is then presented to have a decimal point. The display will show either

TR n	or	TR n
NO DECIMAL (Y/N)		DECIMAL Pt. (Y/N)

When NO is chosen, the other prompt is shown. This continues until YES is chosen. Select the appropriate response depending on the calibration data. If a decimal point is selected, the slope and intercept are as shown on the left below. If a decimal point is not selected, then the same input will appear as shown on the right below. The decimal point is usually used for entering temperature data for display in tenths of a degree.

S: 25.6 I: -256.0	S: 256 I: -2560
T12 (Y/N)	T12 (Y/N)

The new slope and intercept are then displayed. If the data is correct, select YES. If the slope or intercept is not correct, select NO to return to the beginning of Step 6.

STEP 7: **Multiple Channels**

If the decoding type has multiple channels, Step 4 through Step 6 must be repeated for each channel. The transmitter has been setup when the display reads:

SETUP TR#?
(0 TO QUIT)

The data can be verified by entering the transmitter number that was just setup. Press the ENTER key to cycle through the calibration data. A different transmitter can be setup by entering the new transmitter number and repeating Step 1 through Step 7. To exit the transmitter setup routine press 0 followed by ENTER, or simply press ENTER.

The setup is completed when the display reads ENTER COMMAND.

Converting Units

The calibration data supplied with each transmitter contains the slope and intercept for a particular set of units (for example, depth in meters). If the units of display are to be changed, the slope and intercept data must be converted to match the desired units. The following examples show the procedure for depth and temperature. The conversion factors are listed in the table below.

DEPTH:

$$\text{Slope : } 250 \text{ m/s} \times 3.281 = 820 \text{ ft/s} \div 6 = 137 \text{ fath/s}$$

$$\text{Intercept : } -240 \text{ m} \times 3.281 = -787 \text{ ft} \div 6 = -131 \text{ fath}$$

TEMPERATURE:

$$\text{Slope : } (15.5 \text{ }^\circ\text{C/s} \times 1.8) + 32 = 60 \text{ }^\circ\text{F/s}$$

$$\text{Intercept : } (-15.0 \text{ }^\circ\text{C} \times 1.8) + 32 = 5 \text{ }^\circ\text{F}$$

UNIT CONVERSION FACTORS	
PRESSURE:	1 bar = 14.50377 psi 1 psi = 703.1 kg/m ²
DEPTH:	1 psi = 2.307 feet of fresh water at 4 °C 1 psi = 2.244 feet of sea water at 0 °C 1 foot = 0.3048 meters 1 meter = 3.281 feet 1 fathom = 6 feet
TEMPERATURE:	N °C = [(1.8 × N) + 32] °F
CONDUCTIVITY:	1 R* = 42.914003 mmho/cm

* R is the ratio of in situ conductivity to the standard conductivity at Salinity = 35 ppt, Temp = 15 °C, and Press = 0, where Press is the pressure above one standard atmosphere.

INTERNAL BATTERY (OPTION 02)

The power switch has four positions, OFF, ON, CHG (Charge) and AUX (Auxiliary). The VR60 receiver with Option 02 installed is powered with an internal 12 volt Sealed Lead Acid battery.

The ON position will power the receiver from the internal battery. The internal battery receives a float charge if an external power supply is connected when the power switch is in the ON position (**do not** connect the external power with the power switch in the ON position).

To charge the battery, connect the AC charger module to the front panel power jack, with the power switch in the ON or CHG position. With the switch in the CHG position, approximately 10 hours are required to bring the battery up to full charge (battery voltage 13.5 volts). The battery may also be charged from any other DC power supply, such as an automobile battery and alternator system (min. 15 VDC, max. 18 VDC). An internal regulator will limit the charging current to approximately 300 mA (a 1A fuse is located on the charge/regulator circuit board). When the internal battery is being charged the vent screw (white) on the side of the case **must** be opened.

Use the AUX position on the switch to power the VR60 receiver from an external 12 volt Lead Acid battery without float charging the internal battery.

The basic receiver will run for approximately 100 hours between charges of the internal battery. If the decoder option is installed, battery life is shortened to approximately 50 hours between charges.

VR60 MEMORY (OPTION 03B)

The VR60 memory feature (Option 03B) provides 256K of data storage memory and the firmware to log data telemetry transmitters. The data logging option is intended to compress and store data which would normally be written down from the display or printed through the serial port, during use in the field. The stored data, along with a time record, can later be transferred to a printer or external computer.

Memory Storage Capacity

It is possible to calculate the amount of data that can be stored before the memory is fills. The following table lists the number of bytes required for various functions.

MEMORY STORAGE REQUIREMENTS			
FUNCTION	DISPLAY	# of BYTES	NOTES
Start decode one channel transmitter	DECODING TR#xx FREQ xx.x kHz	5.5	Also saves Parameters such as TEMP (°F), or PRES (psi).
Start decode two channel transmitter	DECODING TR#xx FREQ xx.x kHz	6.5	Also saves Parameters such as TEMP (°F), or PRES (psi).
Store time at each reading	xx:xx:xx:xx	2 - 5	Number of bytes depends on amount of change in time (2 bytes if only seconds changed, 3 bytes if seconds and minutes change, 4 bytes if seconds, minutes, and hours change, etc.)
Store data each reading	xxxx	Y ÷ 2	where Y = number of digits stored (including period)
Change frequency	FREQ xx.x kHz	2.5	

The time required to fill the memory is calculated using the equation below:

$$Time = L \times \left\{ \frac{262144 - h}{(D/2) + B} \right\}$$

where:

- Time = time (in seconds) before memory is full
- L = Log Interval in seconds (see Glosary)
- h = number of bytes required for header
- D = number of digits in transmitted data
- B = number of bytes required to store time

For illustration purposes, assume there is a continuous logging of data, and an average is used for the number of bytes required for time storage. With these assumptions, the time to fill the memory has been calculated in the table below for a number of cases.

SAMPLE TIME TO FILL STORAGE MEMORY			
TRANSMITTED DATA	LOG INTERVAL	CALCULATION	TIME TO FILL MEMORY
123 psi	5 min	$300 \times (262144-5.5) \div [(3/2)+3]$	202 days
123 psi	60 s	$60 \times (262144-5.5) \div [(3/2)+3]$	40.5 days
123 psi	10 s	$10 \times (262144-5.5) \div [(3/2)+2.2]$	8.2 days
123 psi	1 s	$1 \times (262144-5.5) \div [(3/2)+2]$	20.8 hours
123 psi	0.4 s	$0.4 \times (262144-5.5) \div [(3/2)+2]$	8.3 hours
12.3 psi	5 min	$300 \times (262144-5.5) \div [(4/2)+3]$	182 days
12.3 psi	60 s	$60 \times (262144-5.5) \div [(4/2)+3]$	36.4 days
12.3 psi	10 s	$10 \times (262144-5.5) \div [(4/2)+2.2]$	7.2 days
12.3 psi	1 s	$1 \times (262144-5.5) \div [(4/2)+2]$	18.2 hours
12.3 psi	0.4 s	$0.4 \times (262144-5.5) \div [(4/2)+2]$	7.3 hours
123 m 15"C	5 min	$300 \times (262144-6.5) \div [(5/2)+3]$	165.5 days
123 m 15"C	60 s	$60 \times (262144-6.5) \div [(5/2)+3]$	33.1 days
123 m 15"C	10 s	$10 \times (262144-6.5) \div [(5/2)+2.2]$	6.5 days
123 m 15"C	1 s	$1 \times (262144-6.5) \div [(5/2)+2]$	16.2 hours
123 m 15"C	0.4 s	$0.4 \times (262144-6.5) \div [(5/2)+2]$	6.5 hours

NOTE: Due to the data compression within the memory storage board, the data in 256k bytes of storage memory will take more than 1600k bytes of disk storage after downloading to a computer (see *Print Data* section).

Log Setup

Before decoding and logging a data telemetry transmitter, the time and the Log Interval (see Glossary) should be set in the *Setup* routine (see *Setup* section of *Option 01*). The Log Interval prompt shown on the display is:

LOG Int. 0 S
(Y/N)

The Log Interval is intended to provide the option of saving data storage memory by reducing the number of data entries into memory.

Decoding and Logging

While decoding a transmitter (see *Decode Transmitters* section), the logging of data can be turned on or off with the keypad by pressing the LOG key ('+' key then DECODE key).

A visual indication in the upper right hand corner of the display appears when data logging is enabled, and flashes when data is stored to memory. When the indicator appears like a boxy "U" then the memory is empty. As the data storage memory fills, this indicator gradually becomes a solid block and will then become an asterisk (*) to indicate that the memory is full. The memory position ranges from 0 (memory empty) to 262144 (memory full). The memory counter is in the format x;y where x is the page (0,1,2 or 3) and y is the counter for each page (0 to 65535). The exact amount of memory that has been used can be checked by pressing the NEXT key. For example, the display shown below indicates that data is being decoded from transmitter TR# 10, the memory position is 10787 on page zero, and the time is 11:32:10 of the 15th day.

```
TR# 10 0,10787  
TIME 15:11:32:10
```

If an asterisk (*) has replaced the block, pressing the NEXT key will show either

```
TR# xx 3,65535  
MEMORY FULL
```

which indicates the memory is full and no more data will be stored, or

```
TR# xx yyy  
Mem write ERROR
```

which indicates that there is a problem with the data storage memory. If a memory error occurs, record the memory location yyy and contact VEMCO.

Retrieve Data from Memory

Stored data can be viewed on the display, printed through the serial port to a printer, or sent through the serial port to an external computer. The memory position where data is stored starts at zero and fills to position 262144. If there is old data stored in memory, for example from a previous field study, the new data will start at the first available memory position. To reset the memory position to zero, the memory must be erased (see *Erase Data* section). It is recommended that the memory be erased before each field study, or after the data has been down loaded to a computer and analyzed.

The retrieve data routine has the structure as shown below:

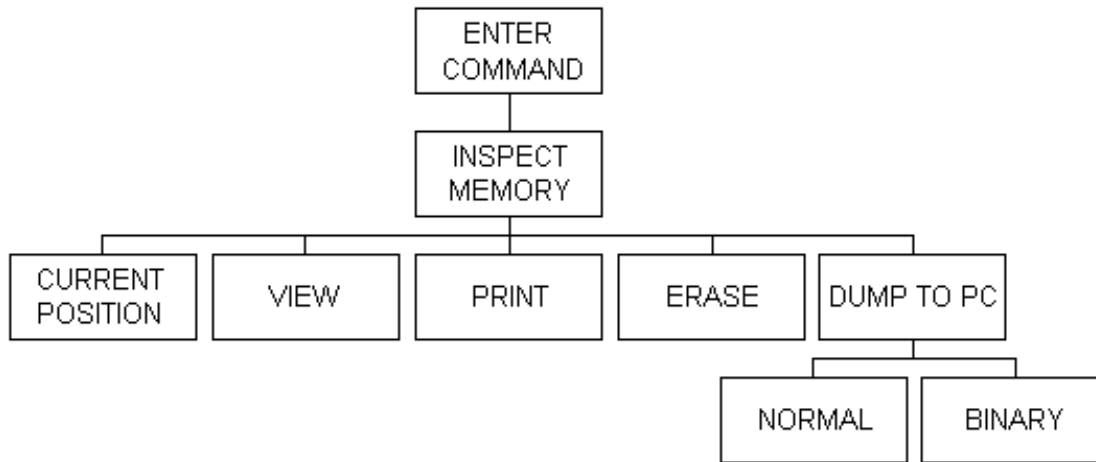

To download data to an IBM compatible computer, use the *Load VR60 Data* command in the appropriate software. It is possible to download data to a computer using the DUMP command on the VR60 receiver. Do not use the PRINT command to download data to a computer. The DUMP command is faster and the data is formatted in such a way as to minimize disk storage space.

To enter the INSPECT MEMORY routine from the ENTER COMMAND prompt, press the + key, then the **LOG** key, and finally the **SETUP** key. The display will then show the following prompt:

View(1) Print(2)
Erase(3) Dump(4)

Press either 1, 2, 3 or 4 to choose one of the four functions, or press NEXT to show the current memory position. To exit back to the ENTER COMMAND level, press ENTER.

View Data

The VIEW command is entered by selecting '1' after entering the INSPECT MEMORY routine. The display then shows "View. start at?" on the first display line and "(Page 0, 1, 2, 3)" on the second line. Enter the desired page number and select ENTER on the keypad. The counter position is then requested for the memory position at which to begin viewing. The display will show the requested counter position to verify that it is the correct location. Press YES to begin viewing, or NO to return to the beginning of the INSPECT MEMORY routine. If YES is selected, the display will read

Any key advance
Enter to quit

as a reminder that the receiver is in view mode. Press any key (other than ENTER) to advance to the memory position. Continue to press any key to advance through the data. Press ENTER to stop the viewing process. When ENTER is selected, the display will indicate that the viewing process has been aborted and to press any key.

Four messages may appear (each beginning with an asterisk) while viewing data: Invalid Data, No Data, Reached Pointer (reached the end of stored data), and End of Memory (at data position 3, 65535).

Print Data

The PRINT command is entered by selecting '2' after entering the INSPECT MEMORY routine. The display then shows

Print. start at?
(Page 0, 1, 2, 3)

Enter the desired page number (either 0, 1, 2, or 3) and select ENTER. The counter position is then requested for the memory position at which printing is to begin. The display shows the requested counter position to verify that it is the correct location. Press YES to continue, or NO to return to the beginning of the INSPECT MEMORY routine. If YES is selected, the display requests a delay time (in milliseconds) after each line is printed for compatibility with mainframe computers. Select the correct baud rate from the choices of 9600, 1200, or 300 baud. Once the baud is selected, the data will be shown on the display and sent to the serial port for printing to an external printer. The printing will stop at the end of the data unless ENTER is pressed. If the NEXT key is pressed then the current memory position is shown on the display. The printing can be stopped temporarily by holding down any digit key.

If the computer does not appear to be receiving data, or if the data consists of strange characters, check the baud rate on the VR60 receiver and on the computer. Use a continuity meter to ensure the RS232C cable is consistent with the diagram in the back of this manual.

Erase Data

When storing data, the memory position automatically increments from the current position to the last position (262143). The only way to change the memory position, other than storing more data, is to erase the data. The memory position will always be zero after the data is erased. The ERASE command is usually used after data has been fully collected and either printed or dumped to an external computer.

The ERASE command is entered by selecting '3' after entering the INSPECT MEMORY routine. The display then reads "Erase. start at 0 (Y/N)". Press NO to abort without erasing, or YES to continue. If YES was selected the display shows:

ABOUT TO ERASE !
ABORT? (Y/N)

This is the last chance to abort the erase. Press YES to abort the erase or NO to execute the erase. If YES is selected, the display will read "ABORTING ERASE" to indicate that the data will not be erased. If NO is selected, the display reads "ERASING..."

During the erase procedure, an exhaustive memory check is performed. The display reports how much memory is installed in the receiver and the condition of that memory. The display will show one of the following responses:

262144 bytes OK	Memory Failure
Press ENTER	Press ENTER

If a memory failure occurs, contact VEMCO for assistance.

Dump Data

The DUMP data routine is for dumping data to an IBM compatible computer using the appropriate software program (see *Available Software* section). Data can be downloaded either by a normal dump of non-compressed data to a file, or by a faster binary dump of compressed data to a smaller file. It is suggested that the software be used to perform a download dump as the procedure is less complicated.

Normal Download of Data (non-compressed)

To download data from the VR60 receiver to a disk file on an IBM compatible computer:

1. Connect a serial connector between the VR60 receiver and the computer.
2. Run the software program.
3. Under the *Defaults* menu, select the *Serial Port* option to set the port number and baud (see applicable software manual).
4. Power the VR60 receiver and answer YES to the KEYPAD (Y/N) prompt.

5. Enter the INSPECT MEMORY routine (press the + key, then the **LOG** key, and finally the **SETUP** key).
6. Select the DUMP command by pressing '4'. The display reads: Normal(1), or Binary Dump(D).
7. Press '1' to select Normal. The display then reads "Normal start at 0 (Y/N)".
8. Press YES to continue, or NO to abort.
9. Choose the baud rate to match the computer baud set in Step 3 by pressing NO until the desired baud is shown. **Do not** press YES at this time.
10. Clear the terminal window using the *Clear Window* option found in the *Terminal* menu.
11. Open *Save incoming Data* (F2) in *File* menu of the VR60MON software and select/create the file name. Everything received on the serial line will be saved to this file.
12. Begin the data dump by pressing YES on the VR60 receiver while the display shows the desired baud rate. The display on the VR60 receiver will read Sending Data and the computer screen will show the incoming data.
13. Press NEXT on the VR60 keypad to view the memory counter position on the display, or ENTER to abort the data dump.
14. When the data dump is complete the VR60 display will show:

*Reached Pointer (i.e. end of data)
 *Press any key

When the data dump is complete, select *Close Data File* (F3) command on the computer to close the data file.

Binary Download of Data (compressed)

For studies which collect large blocks of data (64k or more), download the data in a compressed binary form and later decompress it to a hard disk computer system. This reduces the dump time from hours to minutes as the data stored in 256K of the VR60 receiver memory may take more than 1600K of disk space.

Use the appropriate software (see *Available Software* section) to download compressed data to a data file and to decompress the data.

Battery Replacement on the Memory Board

A lithium battery (Tadiran #TL-5903) is installed on the memory board and will retain data for more than one year. For data reliability, a yearly replacement of this battery is recommended. Be sure any data stored in the VR60 is downloaded to a computer **before** replacing the battery.

There are two methods used to replace the battery, depending on how the battery is attached to the board. If the battery is in a battery holder, follow the steps listed below to replace the battery:

1. Verify that the power switch is in the OFF position.
2. Open the VR60 receiver case (see *To Open VR60 Receiver Case* section).
3. Remove the lithium battery from the data storage board.
4. Place the new lithium battery on the board, making sure to align the positive (+) marking on the battery with the markings on the battery holder. **Inserting the battery in backwards will seriously harm the electronic components.**

If the battery is soldered to the memory board, follow the steps listed below to replace the battery:

1. Verify that the power switch is in the OFF position.
2. Open the VR60 receiver case (see *To Open VR60 Receiver Case* section).
3. Remove the lithium battery from the data storage board with a soldering iron.
4. Solder the new lithium battery on the board, making sure to align the positive (+) marking on the battery with the markings on the printed circuit board. **Inserting the battery in backwards will seriously harm the electronic components.**

IMPORTANT: After replacing the data storage battery, erase the data (see *Erase Data* section). If the data is not erased, the print or view routines will not be able to locate the END OF DATA pointer and will display random data residing in memory.

EXTENDED CABLE (OPTION 04)

The VH65 hydrophone cable length supplied with the VR60 receiver is 5 meters. Additional cable length is available at the time the hydrophone is manufactured. The additional length order is referred to as Option 04. Contact VEMCO for information on available lengths.

CODED TRANSMITTER (OPTION 07)

A VR60 receiver with coded transmitter capability (Option 07) should be setup using the VR60PC software (see VR60PC Software manual). Without the VR60PC software, the receiver is limited to the factory setup. The CHANNEL knob on the front of the VR60 *must* be in the external (EXT) position for coded transmitters to be detected.

To enter *Coded* mode on a VR60 receiver, press the '+' key followed by the '8' key on the keypad at the ENTER COMMAND prompt. If the desired frequency is not shown in the list of frequencies, it must be added to the VR60 receiver setup using the VR60PC software program.

NOTE: If there is only one frequency setup in the VR60 receiver, the receiver will not request a frequency selection. The frequency will be displayed.

When the frequency has been selected, the LCD display will briefly display the frequency, as shown below.

```
CODED FREQUENCY
IS 69.0 kHz
```

When a transmitter is received by the VR60, the top line in the display will indicate the arrival of the sync pulse (designated by a capital S) and each successive pulse (designated by a black rectangle \$\$). If a tag has been previously detected, the bottom line will display the ID code last detected (see below).

```
S $$ $$ $$ $$ $$ $$
ID: 128
```

When the last pulse has been received, the information for that transmitter will be displayed. This information includes the channel, the transmitter type, the ID number, and if applicable the telemetry data and unit. The sample below shows the display for a coded 256 telemetry tag.

```
CH:C 256 SENSOR
ID: 128 56.8m
```

If no signal is received after eight seconds of monitoring, the top line of the display will read "NO SIGNAL". If a detection is made but part of the pulse train is missed, the display will read "INVALID CODE" or "WAITING FOR SYNC".

NOTE: If the top line of the display does not contain the channel ID and the transmitter type, as shown above, the information displayed on the bottom line (coded ID number and telemetry data if applicable) is not current. The code ID and telemetry data remain on the bottom line until the next complete pulse train is received.

A coded telemetry transmitter's information **must** be entered in the VR60PC software (see the *Adding Telemetry Data* section of the VR60PC Software manual) when the coded frequency setup is sent to the VR60 receiver. If a coded telemetry transmitter is not setup and it is detected by the VR60 receiver, the bottom line of the display will show the ID number of the transmitter with the AtoD data in place of the telemetry data, as shown in the example below.

CH: C 256 SENSOR
ID: 142 AtoD: 183

The AtoD data is the raw received data. The slope and intercept pertaining to that transmitter can be used to convert the raw data to meters or temperature.

To exit the coded transmitter option, press the ENTER key while the VR60 receiver is in signal detection mode.

Transmitter Type

There are four types of coded transmitters available in different sizes. The table below identifies the names and key features of each code type.

Code Type Name	Abbreviation	Number of Available ID Codes	Number of pulses	Telemetry?
256 Pinger	R256	256	6	NO
4K Pinger	R04K	4096	7	NO
256 Sensor	S256	256	8	YES
64K Pinger	R64K	65536	8	NO

Coded Channels

The VR60 receiver can identify four transmitter types on one frequency. This is done by using different sync and bin values on four different channels, referred to as a coded map. The default values assigned to each channel are shown in the table below. The coded map specific to this order is found in the Appendix. The channel values differ depending on the frequency range so as to best fit the transmitter capabilities based on transmitter size and power.

VEMCO Default Coded Map “D”						
Model	Frequency Band	Channel			Code Type	
		#	Sync (ms)	Bin (ms)	Description	Transmitter Abbr.
V8, V8B, V8SC, V16, V16T, V16P	51 - 78 kHz (Blank = 300)	A	401.2	22.3	256 Pinger	R256
		B	380	20	4K Pinger	R04K
		C	360	20	256 Sensor	S256
		D	340	20	64K Pinger	R64K
V22, V22T, V22P	30 - 50 kHz (Blank = 650)	A	800	30	256 Pinger	R256
		B	770	30	4K Pinger	R04K
		C	740	30	256 Sensor	S256
		D	710	30	64K Pinger	R64K
V32, V32T, V32P, Chat	27 - 34 kHz (Blank = 750)	A	1000	40	256 Pinger / Chat	R256
		B	960	40	4K Pinger	R04K
		C	920	40	256 Sensor	S256
		D	880	40	64K Pinger	R64K

NON-STANDARD PRESELECTED FREQUENCIES (OPTION 08)

There are eleven preset channels available with the front panel rotary switch labelled CHANNEL. The standard frequencies are listed in the VR60 Receiver Specifications section of the Appendix. When these are not the desired frequencies, a second set of frequencies are available and referred to as Option 08. This second set of frequencies are listed in the table below.

CHANNEL NUMBER	PRESET FREQUENCY (kHz)
CHAN #1	51
CHAN #2	54
CHAN #3	57
CHAN #4	60
CHAN #5	63
CHAN #6	66
CHAN #7	69
CHAN #8	72
CHAN #9	75
CHAN #10	78
CHAN #11	81

AVAILABLE SOFTWARE PROGRAMS

SOFTWARE PROGRAMS

There are two software programs available for use with the VR60 receiver: VSCAN and VR60PC. The software program used depends on the study being performed and the options installed in the VR60 receiver hardware and firmware (see *Option Combinations and Applicable Software* section). For a detailed explanation of a software program, see the appropriate software manual.

VSCAN

The VSCAN software allows information pertaining to the setup of Options 01, 03B, and 05 to be loaded to the VR60 receiver. The software receives GPS data on a second serial port and inserts it into the data file (the receiver must remain connect to the computer). Multiple frequencies may be set in the VSCAN software and it will instruct the VR60 receiver to scan through these frequencies. The VSCAN program is used with telemetry transmitters only (no pingers).

Information pertaining to telemetry transmitters may be loaded to the VR60 receiver through the VSCAN program. The receiver can then be used in the field, although any frequency changes must be made manually. If Option 03B is included, the data may be logged in the field and downloaded to the computer at a later time.

VR60PC

The VR60PC software allows information pertaining to the setup of Options 01 and 07 (including coded telemetry transmitters) to be loaded to the VR60 receiver. The receiver setup may be downloaded to the software. Incoming pulse stings may be viewed if the receiver is connected to the software and the terminal window is open.

OPTION COMBINATIONS AND APPLICABLE SOFTWARE

The table below lists the option combinations available with the VR60 receiver. Option 02 and Option 04 are both available with any combination listed below.

Option Combinations	Software Available
VR60-01 VR60-01-03B	VSCAN
VR60-01-07 VR60-01-03B-07	VR60PC

NOTE: The VR60-01-03B-07 receiver does not log (Option 03) while in coded mode (shift 8).

Setup of VR60 Receiver Software

The VR60 receiver and the IBM compatible computer must be connected with a serial cable in order to communicate with each other. A serial cable is included with the VR60 Receiver (25 pin male / 9 pin female). The 9 pin female end is connected to the computer (either com 1 or com 2) and the 25 pin male end is connected to the front panel of the VR60 receiver. A 9 pin - 25 pin adapter may be used on the computer port, if needed.

To begin communication between the receiver and the computer, run the appropriate software program as explained in the software manual. Power on the VR60 receiver and respond NO to the "KEYPAD (Y/N)" prompt. Select YES to the "9600 BAUD (Y/N)" prompt. The VR60 receiver can now communicate with the computer.

APPENDIX

GLOSSARY

Bin Size

The Bin Size is for each coded tag is stored in the firmware of that particular tag and is necessary for proper reception of the pulse string by the VR60 receiver.

Blanking Interval

The Blanking Interval is the time after each detected pulse in which echoes and reverberations are ignored. The Blanking Interval should normally be set to 200 milliseconds. In extremely reverberant areas the Blanking Interval may be increased but not to exceed 75% of the shortest transmitter period.

Log Interval

The Log Interval controls the rate at which decoded data is sent to memory. The Log Interval may be between zero and 30000 seconds (over eight hours) and must be entered as seconds. A Log Interval of zero will store all the decoded data in memory. For example, if a Log Interval of one minute is desired, a value of 60 seconds must be entered. The decoded data will be stored to memory every 60 seconds even though the data may be changing at a faster rate on the display.

Sync

The Sync is a value, in milliseconds, which allows the VR60 receiver to receive the acoustic transmissions of the coded tags (pingers and telemetry transmitters) and identify the type of coded tag based on the coded map (see *Coded Channels* section). The Sync is stored in the firmware of each tag.

Print Interval

The time (in seconds) between printing data to the serial port if a printer is setup. The print interval may be between 0 and 100 seconds and is set in the SETUP routine (see *Setup* section).

HARDWARE SPECIFICATIONS

VR60 RECEIVER SPECIFICATIONS

RECEIVER TYPE:	Heterodyne, 455.2 kHz IF.																						
FREQUENCY RANGE:	10 kHz to 99.9 kHz.																						
BANDWIDTH:	500 Hz (Crystal filter 3 dB points)																						
IMAGE REJECTION RATIO:	50 dB.																						
GAIN:	72 dB (Not including hydrophone pre-amp).																						
GAIN CONTROL:	66 dB Dynamic range Automatic Gain Control (AGC), or manual control in 6 dB increments.																						
LOCAL OSCILLATOR:	PLL Frequency synthesizer, 3.2768 MHz reference with 100 Hz channel spacing.																						
NUMBER OF CHANNELS:	900 possible frequency channels under keypad control, if fitted with decoder Option 01.																						
STANDARD CHANNELS:	11 Preset channels available with the front panel rotary switch. Channels are stored in EPROM and can be changed upon request (see Option 08). <table><tr><td>CHAN #1</td><td>12.500 kHz</td></tr><tr><td>CHAN #2</td><td>29.000 kHz</td></tr><tr><td>CHAN #3</td><td>30.720 kHz</td></tr><tr><td>CHAN #4</td><td>31.500 kHz</td></tr><tr><td>CHAN #5</td><td>32.768 kHz</td></tr><tr><td>CHAN #6</td><td>34.000 kHz</td></tr><tr><td>CHAN #7</td><td>50.000 kHz</td></tr><tr><td>CHAN #8</td><td>60.000 kHz</td></tr><tr><td>CHAN #9</td><td>65.536 kHz</td></tr><tr><td>CHAN #10</td><td>69.000 kHz</td></tr><tr><td>CHAN #11</td><td>76.800 kHz</td></tr></table>	CHAN #1	12.500 kHz	CHAN #2	29.000 kHz	CHAN #3	30.720 kHz	CHAN #4	31.500 kHz	CHAN #5	32.768 kHz	CHAN #6	34.000 kHz	CHAN #7	50.000 kHz	CHAN #8	60.000 kHz	CHAN #9	65.536 kHz	CHAN #10	69.000 kHz	CHAN #11	76.800 kHz
CHAN #1	12.500 kHz																						
CHAN #2	29.000 kHz																						
CHAN #3	30.720 kHz																						
CHAN #4	31.500 kHz																						
CHAN #5	32.768 kHz																						
CHAN #6	34.000 kHz																						
CHAN #7	50.000 kHz																						
CHAN #8	60.000 kHz																						
CHAN #9	65.536 kHz																						
CHAN #10	69.000 kHz																						
CHAN #11	76.800 kHz																						
PULSE DETECTION:	Pulse amplitude and width discrimination circuit provides 5 volt logic signal for each pulse detected. A front panel LED is also flashed for visual indication. Sample rate of pulse detector is 1 mSec. Pulses under 5 mSec are rejected as invalid.																						
PULSE ECHO REJECTION:	120 mSec of echo rejection for above. Pulse detection signal and front panel LED.																						
AUDIO OUTPUT:	Internal speaker with volume control on front panel. Audio power output is 300 mW.																						
HYDROPHONE TYPE:	Three pin signal & power connector for hydrophones containing internal preamps. Compatible with CAI CS-40, and all VEMCO hydrophones.																						

VR60 RECEIVER SPECIFICATIONS

POWER SUPPLY: 12 VOLTS DC (10 - 14.5)
-30 mA
-35 mA with hydrophone
-85 mA with Decoder & hydrophone
External power cable supplied. Internal 7.2 AH rechargeable Gel cell battery available as Option 02, provides 50 HRS continuous use.

ACCESSORIES: VH65 omnidirectional test hydrophone on 5 meters of cable, supplied with each receiver.

OPTIONS:

- Option 01: Internal Telemetry Decoder and Display.
 - Option 02: Internal rechargeable battery (AC charger module also supplied).
 - Option 03B: 256K CMOS Memory with independent battery backup and data logging firmware (requires Option 01).
 - Option 04: Additional hydrophone cable length available at time of manufacture.
 - Option 07: Coded transmitter capability (requires Option 03B).
-

VH65 OMNIDIRECTIONAL HYDROPHONE (50-80kHz)

OPERATING FREQUENCY: 50 to 80 kHz, 65 kHz optimum.

BEAM PATTERN: Omnidirectional +/- 2dB.

PRE-AMPLIFIER: 50 dB low noise internal amplifier.

SENSITIVITY: -148 dB re 1 V/uPascal.

NOISE FLOOR: 27 dB re 1 uPascal/SqrtHz. At 65 kHz.

POWER SUPPLY: 12V DC, 5 mA (supplied by receiver).

HYDROPHONE SIZE: 16mm DIA x 100mm length cylinder.

CABLE: 6.5mm dia polyurethane jacket twisted shielded pair with drain wire. Standard length 5 meters; extra length available with Option 04.

CONNECTOR: AMPHENOL MS-3106A-10SL-3S.

V10 DIRECTIONAL HYDROPHONE (50-80kHz)

OPERATING FREQUENCY:	50 to 80 kHz.
OPERATING DEPTH:	5 meters
POWER SUPPLY:	12 VDC 5 mA (supplied by receiver)
DIMENSIONS:	82 mm x 95 mm x 35 mm
CASE MATERIAL:	Machined solid block of Aluminum.
CABLE:	6.5mm diameter polyurethane jacket, twisted shielded pair. Standard length 10 meters; extra length available with Option 04.
CONNECTOR:	AMPHENOL MS-3106A-10SL-3S.
APPLICATION:	The V10 is used for directional tracking. It can be deployed on a hull mount, strut mount ,or on a V-Fin towed depressor.

FREQUENCY (kHz)	50	60	70	80
SENSITIVITY (dB re 1V/uPascal @ 1m)	-144	-141	-142	-145
NOISE FLOOR (dB re 1 uPascal/SqrtHz)	21	20	21	23
HORIZONTAL ACCEPTANCE ANGLE - BANDWIDTH (degrees, between 3 dB points)	30	26	22	18
VERTICAL ACCEPTANCE ANGLE - BANDWIDTH (degrees, between 3 dB points)	150	150	150	150

VH32 OMNIDIRECTIONAL HYDROPHONE (25-35kHz)

OPERATING FREQUENCY:	25 to 35 kHz (3dB bandwidth).
BEAM PATTERN:	Omnidirectional +/- 2dB.
PRE-AMPLIFIER:	50 dB low noise internal amplifier.
SENSITIVITY:	-148 dB re 1 V/uPascal.
NOISE FLOOR:	27 dB re 1 uPascal/SqrtHz. At 32 kHz.
POWER SUPPLY:	12V DC, 5 mA (supplied by receiver).
HYDROPHONE SIZE:	32mm DIA x 100mm length cylinder.
CABLE:	6.5mm dia polyurethane jacket twisted shielded pair with drain wire. Standard length 5 meters; extra length available with Option 04.
CONNECTOR:	AMPHENOL MS-3106A-10SL-3S.

V11 DIRECTIONAL HYDROPHONE (25-35kHz)

OPERATING FREQUENCY:	25 to 35 kHz.
OPERATING DEPTH:	5 meters.
POWER SUPPLY:	12 VDC 5 mA (supplied by receiver).
DIMENSIONS:	116 mm x 184 mm x 57 mm
CASE MATERIAL:	Machined solid block of Aluminum.
CABLE:	6.5mm diameter polyurethane jacket, twisted shielded pair. Standard length 10 meters, extra length available with Option 04.
CONNECTOR:	AMPHENOL MS-3106A-10SL-3S.
APPLICATION:	The V11 is used for directional tracking. It can be deployed on a hull mount, strut mount, or on a V-Fin towed depressor.

FREQUENCY (kHz)	27	32
SENSITIVITY (dB re 1V/uPascal @ 1m)	-145	-143
NOISE FLOOR (dB re 1 uPascal/SqrtHz)	37	35
HORIZONTAL ACCEPTANCE ANGLE - BANDWIDTH (degrees, between 3 dB points)	24	20
VERTICAL ACCEPTANCE ANGLE - BANDWIDTH (degrees, between 3 dB points)	150	150

CODED CHANNELS (order specific)

The VR60 receiver can identify four transmitter types on one frequency. This is done by using different sync and bin values on four different channels, referred to as a coded map. The coded map for this order is shown below.

ORDER NO.: 01-680

DATE: March 26, 2002

CUSTOMER: Wildlife Conservation

VEMCO Coded Map "D"					
Frequency (kHz)	Channel			Code Type	
	#	Sync (ms)	Bin (ms)	Description	Transmitter Abbr.
69	A	401.2	22.3	256 Pinger	R256
	B	380	20	4K Pinger	R04K
	C	360	20	256 Sensor	S256
	D	340	20	64K Pinger	R64K

**REPLACE THIS PAGE FOR THE ORDER SPECIFIC
PAGE PRINTED BY THE TECHNICIAN**

SYSTEM DIAGRAMS

Diagrams include:

- Figure 1 - VR60 receiver board schematic
- Figure 2 - VR60 receiver board layout
- Figure 3 - VR60 controller board schematic - Power
- Figure 4 - VR60 controller board schematic - Analog
- Figure 5 - VR60 controller board schematic - Digital
- Figure 6 - VR60 controller board layout
- Figure 7 - VR60 synthesizer board schematic
- Figure 8 - VR60 synthesizer board layout
- Figure 9 - Hydrophone cable wiring diagram
- Figure 10 - VR60 processor board schematic - Main and connector section
- Figure 11 - VR60 processor board schematic - Microprocessor
- Figure 12 - VR60 processor board schematic - Memory
- Figure 13 - VR60 processor board schematic - Memory storage
- Figure 14 - VR60 processor board layout
- Figure 15 - Serial cable diagram
- Figure 16 - VR60 charger board schematic
- Figure 17 - VR60 charger board layout
- Figure 18 - VR60 dual hydrophone board schematic
- Figure 19 - VR60 dual hydrophone board layout